

2. 80x86 Ailesi Mikroişlemcilerin Mimarisi

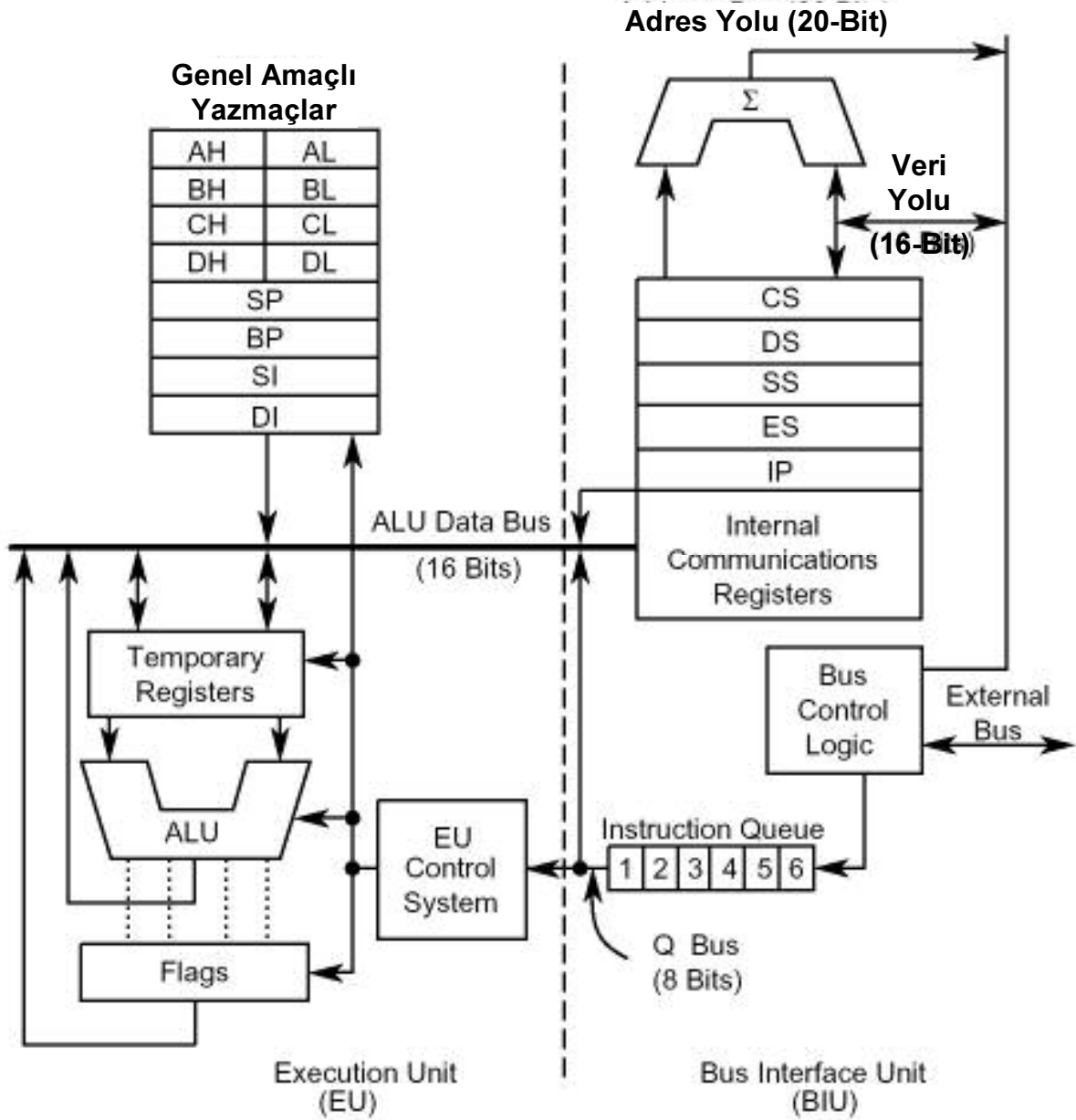

Şekil 2-1 80x86 ailesi mikroişlemcilerin basitleştirilmiş fonksiyonel blok diyagramı

2.1. 80x86 Mikroişlemci Programlama Modeli

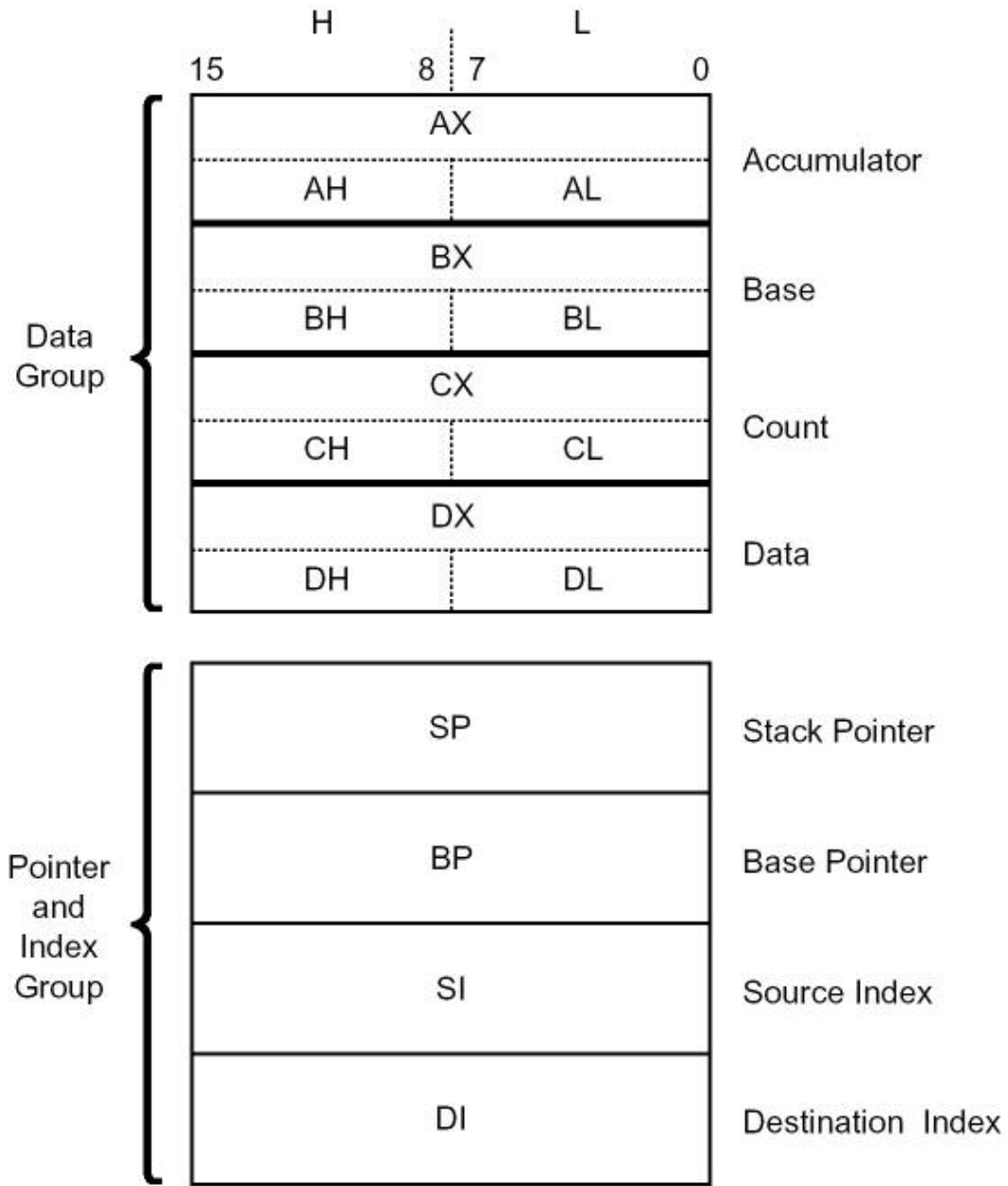

Şekil 2-2 Genel amaçlı yazmaçlar

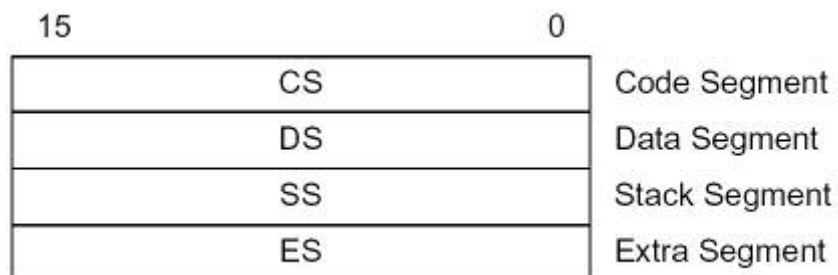

Şekil 2-3 Parça yazmaçları

Tablo 2-1 Genel amaçlı yazmaçların kullanımı

Register	Operations
AX	Word Multiply, Word Divide, Word I/O
AL	Byte Multiply, Byte Divide, Byte I/O, Translate, Decimal Arithmetic
AH	Byte Multiply, Byte Divide
BX	Translate
CX	String Operations, Loops
CL	Variable Shift and Rotate
DX	Word Multiply, Word Divide, Indirect I/O
SP	Stack Operations
SI	String Operations
DI	String Operations

Tablo 2-2 İşlemci Durum Yazmacı

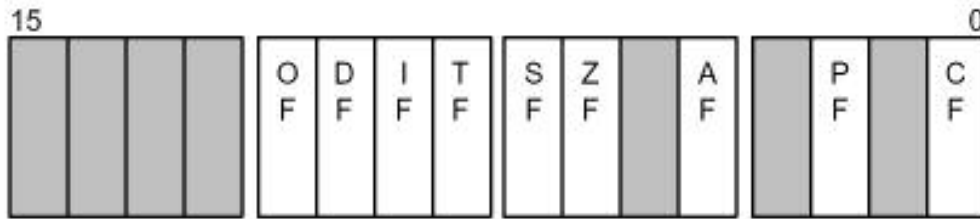

Bit Mnemonic	Bit Name	Reset State	Function
OF	Overflow Flag	0	If OF is set, an arithmetic overflow has occurred.
DF	Direction Flag	0	If DF is set, string instructions are processed high address to low address. If DF is clear, strings are processed low address to high address.
IF	Interrupt Enable Flag	0	If IF is set, the CPU recognizes maskable interrupt requests. If IF is clear, maskable interrupts are ignored.
TF	Trap Flag	0	If TF is set, the processor enters single-step mode.
SF	Sign Flag	0	If SF is set, the high-order bit of the result of an operation is 1, indicating it is negative.
ZF	Zero Flag	0	If ZF is set, the result of an operation is zero.
AF	Auxiliary Flag	0	If AF is set, there has been a carry from the low nibble to the high or a borrow from the high nibble to the low nibble of an 8-bit quantity. Used in BCD operations.
PF	Parity Flag	0	If PF is set, the result of an operation has even parity.
CF	Carry Flag	0	If CF is set, there has been a carry out of, or a borrow into, the high-order bit of the result of an instruction.

2.1.5 Instruction Pointer

The Bus Interface Unit updates the 16-bit Instruction Pointer (IP) register so it contains the offset of the next instruction to be fetched. Programs do not have direct access to the Instruction Pointer, but it can change, be saved or be restored as a result of program execution. For example, if the Instruction Pointer is saved on the stack, it is first automatically adjusted to point to the next instruction to be executed.

Reset initializes the Instruction Pointer to 0000H. The CS and IP values comprise a starting execution address of 0FFFF0H (see “Logical Addresses” on page 2-10 for a description of address formation).

2.1.6 Flags

The 80C186 Modular Core family has six status flags (see Figure 2-5) that the Execution Unit posts as the result of arithmetic or logical operations. Program branch instructions allow a program to alter its execution depending on conditions flagged by a prior operation. Different instructions affect the status flags differently, generally reflecting the following states:

- If the Auxiliary Flag (AF) is set, there has been a carry out from the low nibble into the high nibble or a borrow from the high nibble into the low nibble of an 8-bit quantity (low-order byte of a 16-bit quantity). This flag is used by decimal arithmetic instructions.
- If the Carry Flag (CF) is set, there has been a carry out of or a borrow into the high-order bit of the instruction result (8- or 16-bit). This flag is used by instructions that add or subtract multibyte numbers. Rotate instructions can also isolate a bit in memory or a register by placing it in the Carry Flag.
- If the Overflow Flag (OF) is set, an arithmetic overflow has occurred. A significant digit has been lost because the size of the result exceeded the capacity of its destination location. An Interrupt On Overflow instruction is available that will generate an interrupt in this situation.
- If the Sign Flag (SF) is set, the high-order bit of the result is a 1. Since negative binary numbers are represented in standard two’s complement notation, SF indicates the sign of the result (0 = positive, 1 = negative).
- If the Parity Flag (PF) is set, the result has even parity, an even number of 1 bits. This flag can be used to check for data transmission errors.
- If the Zero Flag (ZF) is set, the result of the operation is zero.

Additional control flags (see Figure 2-5) can be set or cleared by programs to alter processor operations:

- Setting the Direction Flag (DF) causes string operations to auto-decrement. Strings are processed from high address to low address (or “right to left”). Clearing DF causes string operations to auto-increment. Strings are processed from low address to high address (or “left to right”).
- Setting the Interrupt Enable Flag (IF) allows the CPU to recognize maskable external or internal interrupt requests. Clearing IF disables these interrupts. The Interrupt Enable Flag has no effect on software interrupts or non-maskable interrupts.
- Setting the Trap Flag (TF) bit puts the processor into single-step mode for debugging. In this mode, the CPU automatically generates an interrupt after each instruction. This allows a program to be inspected instruction by instruction during execution.

The status and control flags are contained in a 16-bit Processor Status Word (see Figure 2-5). Reset initializes the Processor Status Word to 0F000H.

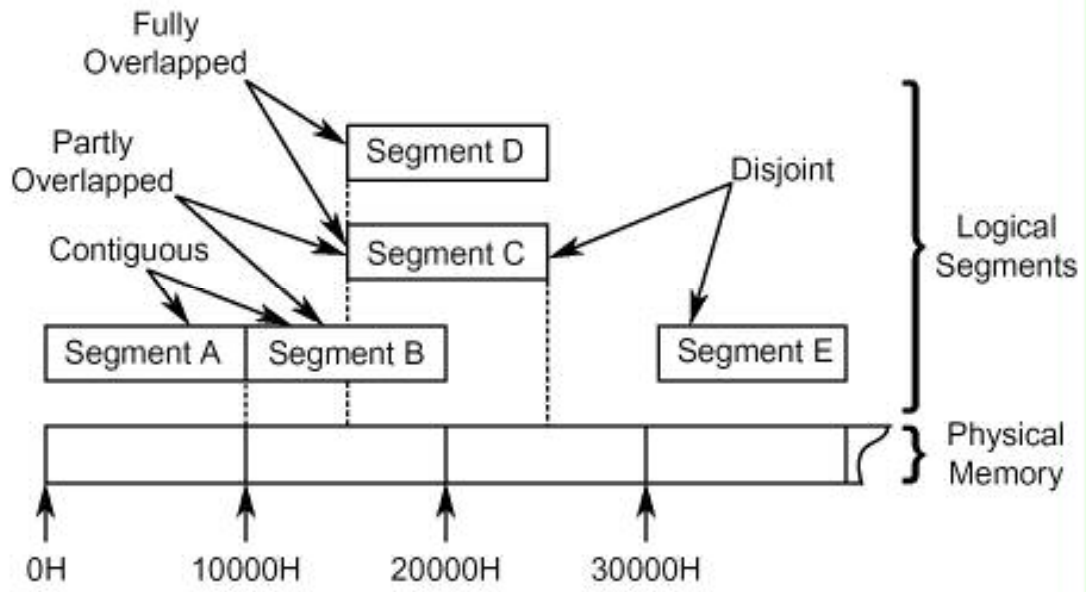

Şekil 2-4 Fiziksel Bellekte Parça Bölgeleri

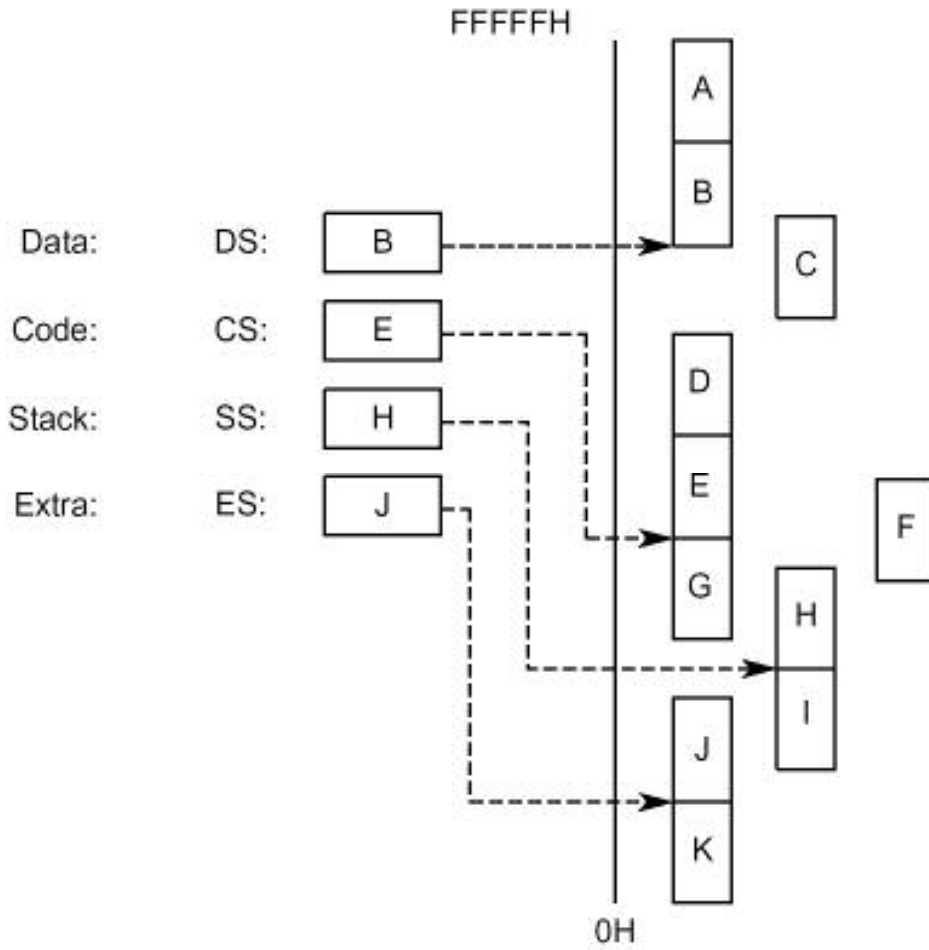

Şekil 2-5 Adreslenebilir Bellek Parçaları

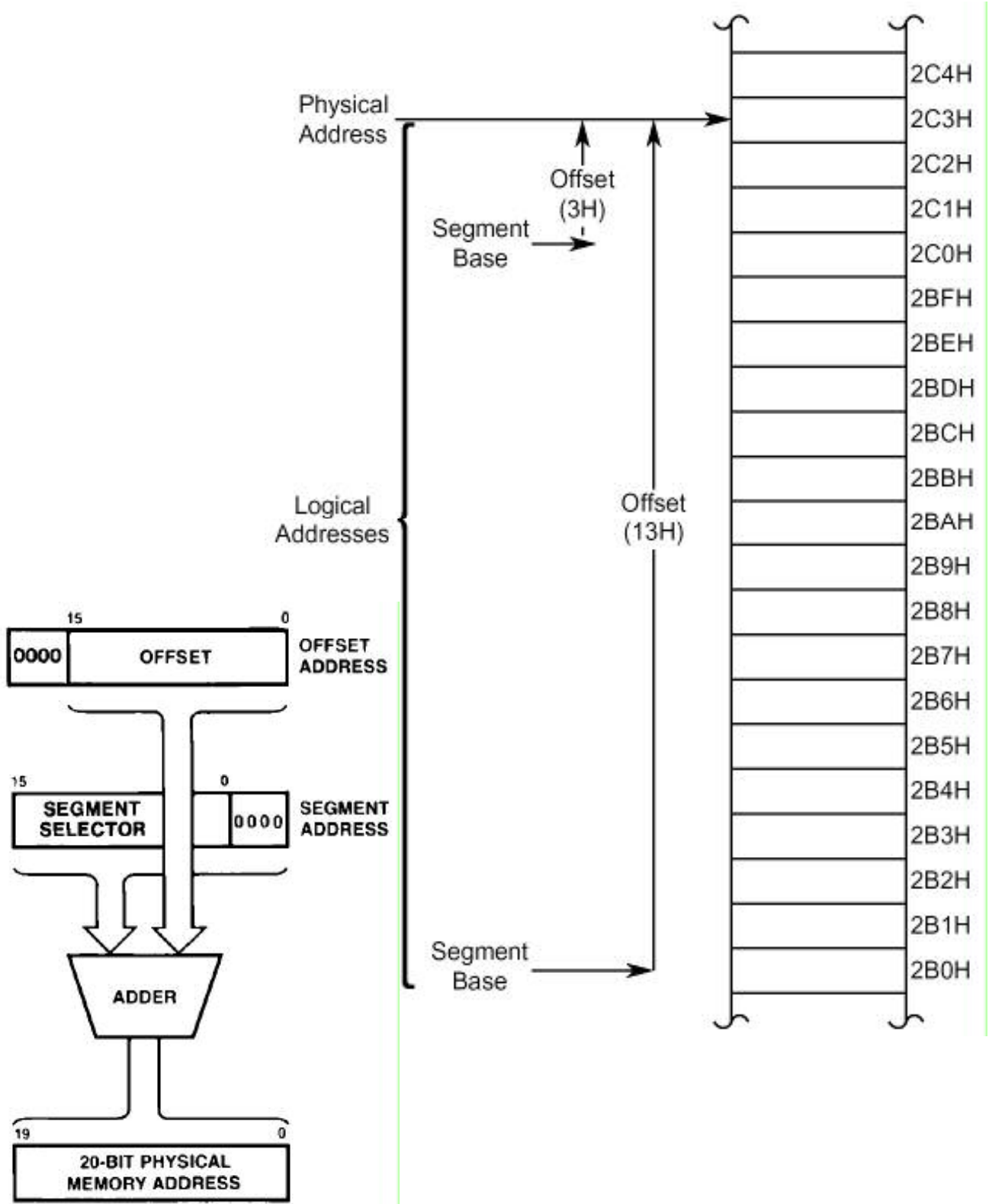

Şekil 2-6 Mantıksal ve Fiziksel Adresler

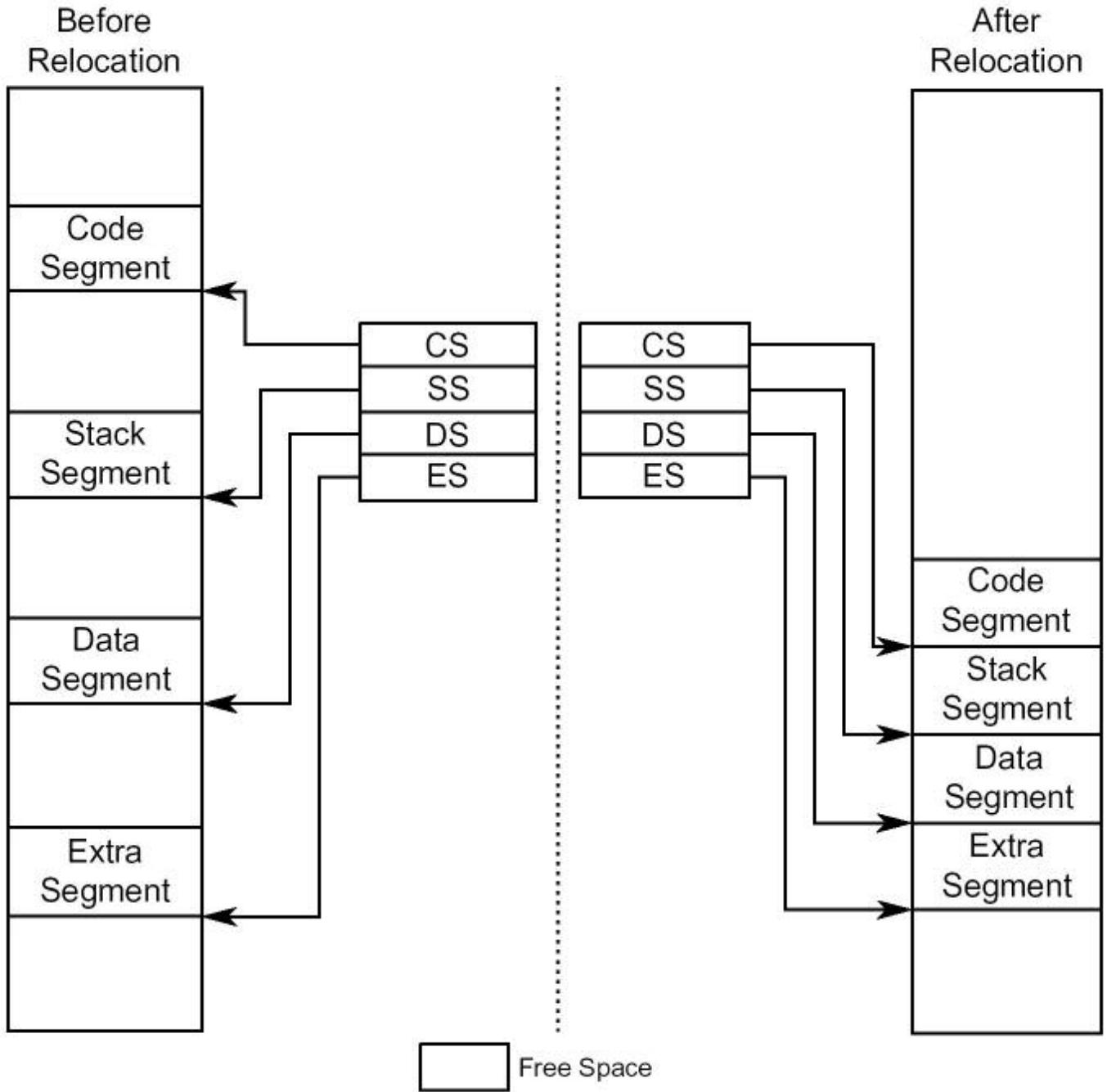

Şekil 2-7 Dinamik kod yer deęiřtirme

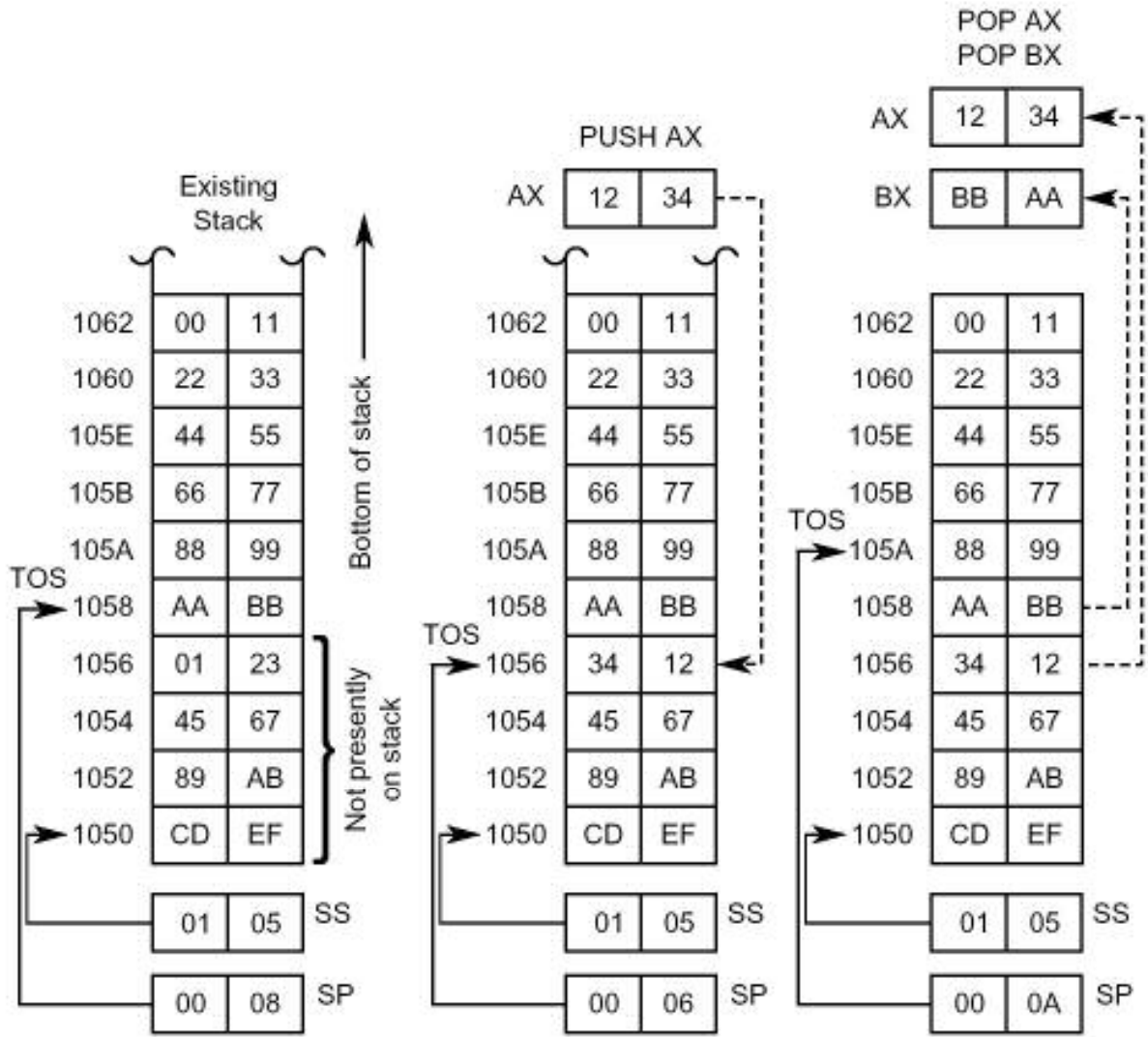

Stack operation for code sequence
 PUSH AX
 POP AX
 POP BX

Şekil 2-8 Yığın İşlemi